



104

ROMA® CHECK VALVE



SIZE	PRESSURE	CODE	PACKING
3/8" (DN 10)	25bar/362.5psi	1040038	10/100
1/2" (DN 15)	25bar/362.5psi	1040012	10/100
3/4" (DN 20)	25bar/362.5psi	1040034	8/72
1" (DN 25)	25bar/362.5psi	1040100	6/48
1"1/4 (DN 32)	18bar/261psi	1040114	4/28
1"1/2 (DN 40)	18bar/261psi	1040112	4/24
2" (DN 50)	18bar/261psi	1040200	2/16

TECHNICAL SPECIFICATIONS

Body in brass.
 Plate in stainless steel.
 Washer in Viton®.
 Spring in stainless steel.
 Outlet plugs in brass, thread 1/4".
 Minimum working temperature: -20°C.
 Maximum working temperature: 100°C with water ;
 150°C with fluid hydrocarbons or compressed air.
 Threads ISO228 (equivalent to DIN EN ISO 228 and BS EN ISO 228).

CERTIFICATIONS



MATERIALS

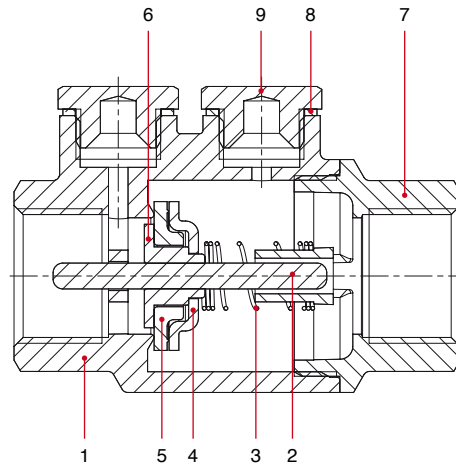

POS.	DESCRIPTION	N.	MATERIAL
1	Body	1	Brass CW617N
2	Pin	1	Brass CW614N
3	Spring	1	Stainless steel AISI 302
4	Plate	1	Stainless steel AISI 304
5	Washer	1	VITON®
6	Plug	1	Brass CW614N
7	End adapter	1	Brass CW617N
8	Washer	2	Aluminium
9	Plug	2	Brass CW614N

OVERALL DIMENSIONS

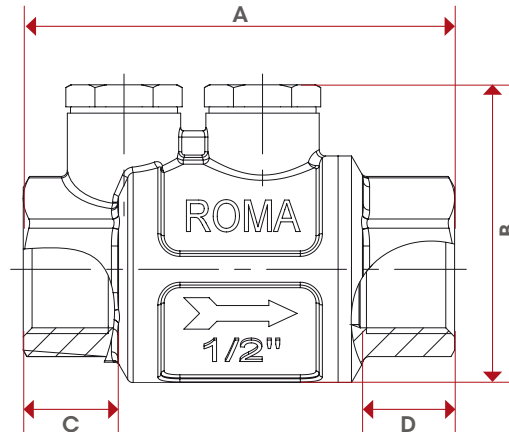

	3/8"	1/2"	3/4"	1"	1"1/4	1"1/2	2"
DN	10	15	20	25	32	40	50
A	63	68,5	69,5	79	84	93,5	108
B	47,3	47,3	54,5	60,8	72,8	83,3	99,3
C	10	13,5	14	15	16	16	20
D	10	14	14	15	15,5	17	19
Kg/cm ² bar	25	25	25	25	18	18	18
LBS - psi	362,5	362,5	362,5	362,5	261	261	261

MANUFACTURER INSTRUCTIONS

Installation

The ROMA® check valves are uni-directional; that means they manage the flow in one direction only, which is indicated by the arrow on the body. The valves are composed by a spring, a little valve and a couple of parts made of brass (body and end-adapter) which contain them and that are assembled by means of thread and a sealed material to obtain their aim. In order to avoid that the sealed material gets broken and then the valve loses the connection between the body and the end-adapter, it's necessary to avoid to submit the two parts under the influence of a torque. For the installation normal hydraulic practices must be used, and especially:

- For a proper installation of the valve, near curves and circulation pumps, the valve must be mounted at a distance equal to 10 times the diameter of the pipe.
- The installer has to be sure that the two pipes are correctly aligned;
- During the assembling process the installer has to apply its assembling tools at the end that is nearest to the pipe;
- The application of the sealing materials by the fitter (PTFE or hempen cloth) must be limited at the thread zone. An excess should interfere in the ball gasket's closure zone, compromising the tightness;
- In case the fluid transported has got some impurities (dust, too hard water, and so on) it's necessary to remove impurities by or filter them, otherwise they could damage the seal.

Disassembly the installed valve

To remove the valve from the pipe line or anyhow before unscrewing the connections linked:

- Wear the protective clothing normally required to work with carried fluids;
- Depressurize the line;
- During the disassembling process, apply the key at the end of the valve, the one nearest the pipe

Maintenance

Verify the valve periodically, according to its application's field and its works' field and its work's conditions, in order to be sure that the valve works correctly. In case of losses of tightening, take note that these can be caused by a deposit of foreign bodies (dirty, calcareous) on the rubber seal. In order to solve this inconvenient, it's necessary to unmount the valve and remove the foreign body with compressed air tools.