

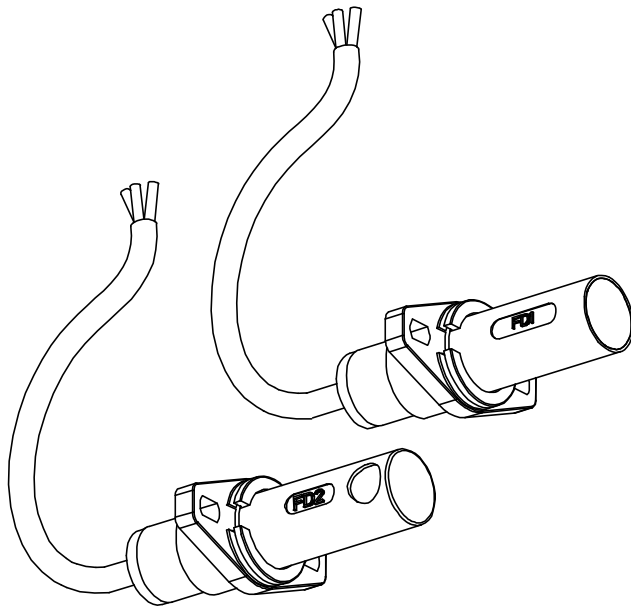

UV SENSOR TYPE FD1/S - FD2/S

FLAME DETECTION DEVICES FOR FUEL OIL AND GAS BURNERS WITH BRAHMA SAFETY DEVICE



INTRODUCTION

The combustion process, depending on the type of fuel used, emits more or less light radiation belonging to the ultraviolet, visible or infrared spectrum.

Of course, gas oil combustion generates a very bright flame, which is easily detectable by means of sensors using common photocells; nevertheless, at the same time gas oil combustion generates a quantity of substances not completely burnt (unburnt substances), which pollute and also dirty the combustion chamber step by step.

By suitably adjusting the combustion, it is possible to solve this problem and improve the flame quality, making it similar to the flame produced by gas, natural gas or propane combustion (blue flame).

Since photocells are not sensitive to blue flame light, in most gas burners the presence of flame is detected by exploiting the ionization principle; to this purpose, you simply need an electrode (electrically isolated metal rod) suitably "immersed" in the flame. This principle is not easily applicable in oil burners, as the electrode immersed in the flame gets dirty quickly (consequently losing its efficiency) and modifies the turbulence in the combustion chamber, thus creating serious problems.

For all these reasons, it is necessary to detect the presence of flame by means of ultraviolet sensitive detectors.

The FDx/S sensor has also proved suitable for gas applications where the use of an electrode, for example for high temperatures, is not possible.

DESCRIPTION

The FDx/S sensor uses a silicon preamplified active element, specifically designed for blue flame burner applications; the UV light peak detection of this sensor is around 310 nm.

An adequate electronic boundary placed inside the device renders it compatible with all BRAHMA devices with a gas application.

In particular is suited with DS11, DS11P, DSM11, DSM11P and SM592N/S. It's strongly recommended for single electrode applications DSM11 and DSM11P

In order to meet the widest range of market requirements, this device is available in the FD1/S version (with front view) and in the FD2/S version (with lateral view). In application where the flame is far from the point of detection an high sensitivity sensor can be required.

Please note that the FDx detector is sensitive to the ultraviolet component of visible light; therefore, its use is recommended in burners fitted with closed combustion chambers and in an application environment perfectly shielded from visible light.

FEATURES

- Supply voltage	220-240V @ 50/60Hz
- on request:	110-120V @ 50/60Hz
- Power consumption	1VA
- Visible band	290-350nm
- Reception angle	8°
- Max. output current	50µA
- Operating temperature range	-20 to +60°C
- Max. humidity	95%

FD1/S mechanical features

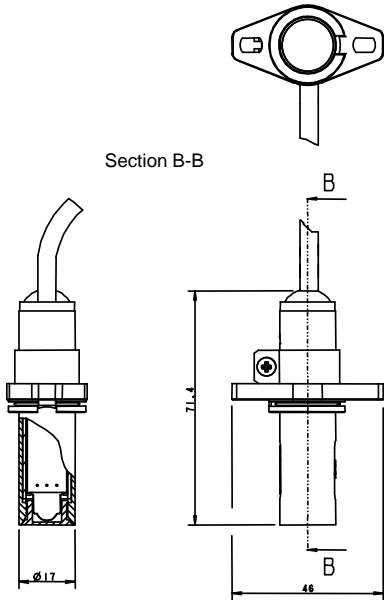

WARNINGS

For a correct and safe use of FDx/S sensors, please follow the directions below:

- Place the device so as for the flame light to strike the field of view (8°).
- Avoid placing unsuitable transparent materials between the sensor and the flame light to be detected; e.g., glass shows filter (shield) features towards the light ultraviolet component.
- Avoid installing the device close to heat sources, which may cause inner temperature increase and consequently damage the sensor.
- Avoid wiring the FDx cable with ignition or high voltage cables.
- Only use the FDx/S device in conjunction with BRAHMA-produced ignition and flame control equipment with gas applications.

WIRING DESCRIPTION

- | | |
|--------------|---------|
| - Brown wire | Live |
| - Blue wire | Neutral |
| - White wire | Output |

FD2/S mechanical features

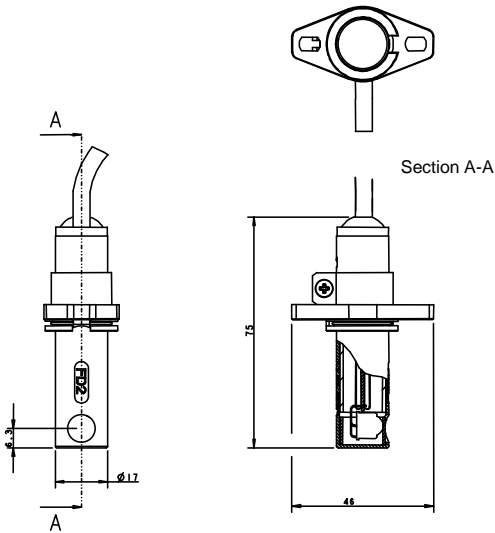

APPLICATION EXAMPLE

The following diagram shows an application example of the FDx/S sensor with ignition and control flame devices type DS11, DS11P, DSM11, DSM11P and SM592N/S.

In order to connect the sensor to other gas devices produced by BRAHMA, please refer to relevant product's technical notes.

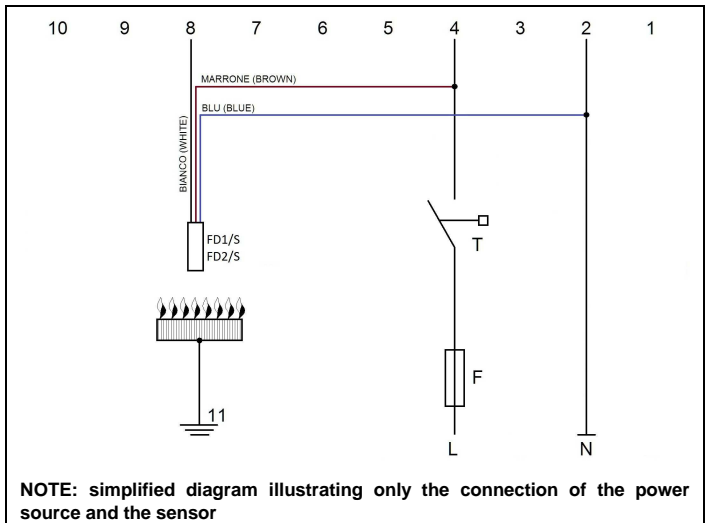

NOTE: simplified diagram illustrating only the connection of the power source and the sensor

Drilling plane

For FD1 and FD2

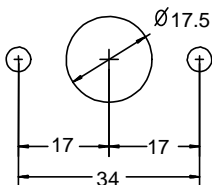

SENSORS DENOMINATIONS

Type

FD (a) /S (b)

Type description

- (a) **Kind of view**
- 1: front view
 - 2: lateral view
- (b) **Kind of BRAHMA control box connected with the sensor**
- No letter: standard sensitivity
 - H: high sensitivity

Examples of denominations:

- 1) FD1/S: sensor with front view, used with BRAHMA control boxes.
- 2) FD2/S H: sensor with lateral view, used with BRAHMA control boxes; high sensitivity.

ATTENTION ->Company Brahma S.p.A. declines any responsibility for any damage resulting from the Customer's interfering with the device.

BRAHMA S.p.A.

Via del Pontiere, 31
37045 Legnago (VR)
Tel. +39 0442 635211 - Telefax +39 0442 25683
<http://www.brahma.it>
E-mail : brahma@brahma.it

12/03/13 Subject to amendments without notice