

PHOTOCELLS

FLAME SENSORS FOR FUEL OIL BURNERS

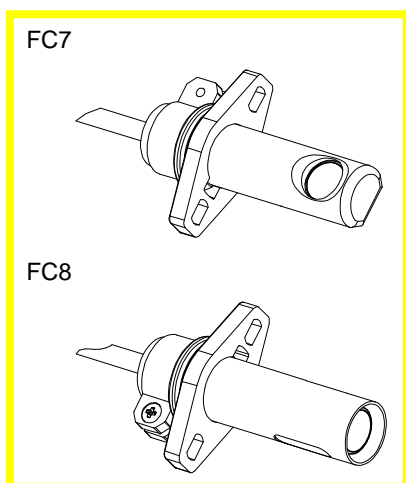

FC7

FC8

FC9

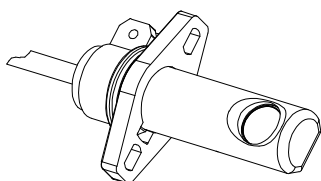

FC11

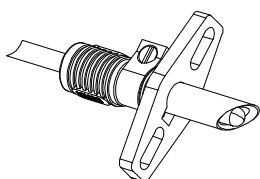

FC13

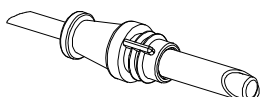

FC14

FC14L

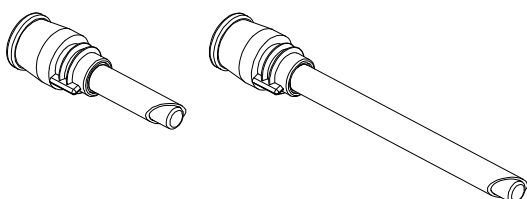

Introduction

Flame detection in fuel oil burners occurs by means of sensors detecting the presence of flame through an electrical signal, which can be used by ignition and control devices.

Generally, to detect the presence of flame in these appliances a photocell is used, which exploits the light generated by the flame itself.

Description

These are the most used flame sensors for fuel oil burners. Photocells vary their ohmic resistance according to the light incidence; this property is exploited to detect the occurred flame generation in burners.

Various types of photocells are available, differing from each other in their application and casing. Fig.1 shows the FC7, FC8 and FC9 photocells; the difference between FC7 and FC8 models consists in the detecting element, which lights up laterally in the FC7 and frontally in the FC8. The FC9 photocell is suitable to be light up laterally; an inbuilt diode enables this photocell to be used with particular devices (for example Brahma 32CN). Fig.2 shows the FC11, FC13 and FC14 photocells, differing from each other only in the fixing system, as both of them light up laterally and frontally. Fig.3 shows FC14 and FC14L photocells, differing from each other in the case length, even if both of them are able to be light up laterally and frontally. They are provided with a connection plug which facilitates assembly and maintenance operations. The standard length of the photocell connecting cable is 600mm; the operating temperature range ensuring the longest life of flame sensors (approximately 50,000 hours) is comprised between 0°C and +60°C.

Sensitivity

The sensitivity of photocells can be identified through the colour of their casing, according to the following directions:

/N	Black
/R	Red
/A	Blue
/V	Green

The colour red indicates photocells with standard sensitivity, the colour blue corresponds to the most sensitive photocells, whereas the colour green marks the least sensitive photocells.

For the right coupling between photocell and control device please refer to our technical literature regarding control devices making use of these flame sensors.

Followings are the sensitivity ranges of the available flame sensors:

Lateral side	FC7/R	1,5..5,5	lux
	FC7/A	1,5..3,0	lux
	FC7/V	3,0..5,5	lux
Frontal side	FC8/R	1,5..5,5	lux
	FC8/A	1,5..3,0	lux
	FC8/V	3,0..5,5	lux
Lateral side	FC9/N	1,5..5,5	lux
	FC9/A	1,5..3,0	lux
	FC9/V	3,0..5,5	lux
Frontal and lateral side	FC11/N	1,5..6,5	lux
	FC11/A	1,5..3,0	lux
Frontal and lateral side	FC13/R	1,5..6,5	lux
	FC13/A	1,5..3,0	lux
Frontal and lateral side	FC14/R	1,5..6,5	lux
	FC14/A	1,5..3,0	lux
Frontal and lateral side	FC14L/R	1,5..6,5	lux
	FC14L/A	1,5..3,0	lux

FC7, FC8 e FC9 models

- FC7 e FC9

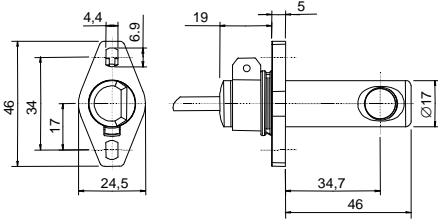

- FC8

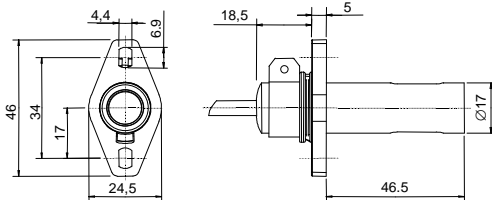

Drilling plane FC7, FC8 e FC9

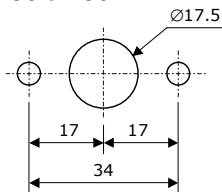
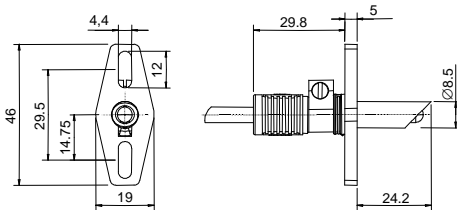

Fig.1

FC11, FC13 e FC14 Models

- FC11



- FC13

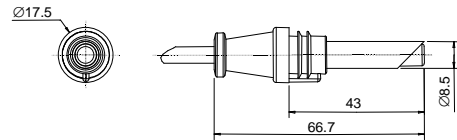
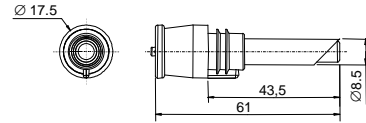

Fig.2

- FC14



- FC14L

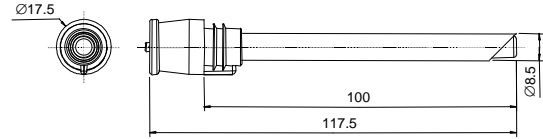
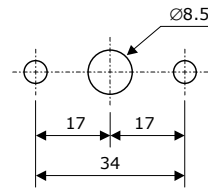
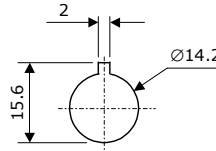

Fig.3

Drilling plane FC11



FC13 and FC14 drilling plane (fastening system for the mechanical interference with the photocell case)



Ø4mm screws are recommended to fasten FC7, FC8, FC9 and FC11 flame sensors.

Accessories

The cable for FC14 and FC14/L photocells is an accessory. The standard cable length is 620mm (cables having different length are available upon request).

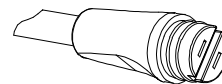

The photocells can be provided upon request with a protection cap for the detecting element to protect it against damage in case of impact

ATTENTION -> Company Brahma S.p.A. declines any responsibility for any damage resulting from the Customer's interfering with the device

BRAHMA SpA

Via del Pontiere,31
37045 Legnago (Vr)
Tel. +39 0442 635211 – Telefax +39 0442 25683
http:// www.brahma.it
E – mail: brahma @ brahma.it

2007/12/04 Subject to amendments without notice