

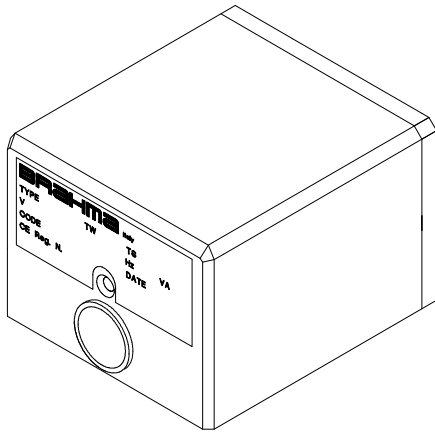

## EUROGAS SERIES TYPES VM41 VM42

### AUTOMATIC CONTROL SYSTEMS FOR FORCED DRAUGHT BURNERS FOR GASEOUS FUELS



#### DESCRIPTION

The automatic control systems of this series are suitable to control forced draught burners for gaseous fuels for non-permanent operation.

All these controls perform non-volatile lock-outs, condition from which a restart of the system is only possible by means of the control manual reset.

This range of controls is suitable to equip burners for domestic and industrial heating. The VM41 control is suitable for single flame applications, while the VM42 control is suitable for dual flame applications.

#### GENERAL FEATURES

The main features of this range are the following:

- EC - Type certification (CE Reg. N° 63AQ0625) in accordance with Gas Appliance Directive 90/396;
- in accordance with EN 298 (European standard for automatic gas burner control systems), prEN 676 (European standard for automatic forced draught burners) and DIN 4788 (German standard for automatic forced draught burners);
- flame monitoring by the rectification property of the flame (ionization);
- two independent safety contacts for the gas valve control;
- electrical service life at max.declared loading >250.000 operations;
- inbuilt manual reset;
- easy to install and wire;
- interchangeable with the relevant mechanical controls as regards operation and dimensions;
- max. burner output for VM41:
  - 120KW according to prEN 676;
  - 350KW according to DIN 4788;
- max. burner output for VM42: no limits.

#### TECHNICAL DATA

**Power supply:** 230V-50/60Hz  
upon request: 110/120V-50/60Hz

**Operating temperature range:** -20°C +60°C

**Ambient humidity:** 95% max. at 40°C

#### Protection degree:

socket type NE IP 40

socket type N IP 40

#### Classification code (according to EN 298):

VM41 FMCLXN

VM42 FTLLXN

Flame failure during TS causes spark restoration.

#### Times:

-Prepurge time (TW) 20/30/40/50/60 s

-Safety time (TS):

VM41: 2/3/4/5 s

VM42: 2/3 s

-Drop out time on running flame failure: < 1 s

The times given on the burner control label correspond to the values guaranteed. The actual values differ slightly from the values given, pre-purge and waiting times are in fact longer and safety time shorter than their nominal values.

	VM41	VM42
<b>Power consumption, at starting up:</b>	12 VA	15VA
<b>Power consumption, running:</b>	9 VA	12VA
<b>Contact rating:</b>	I max	
-Thermostat:	6 A	$\cos\phi > 0.4$
-EV1:	0.5 A	$\cos\phi > 0.4$
-EV2:	0.5 A	$\cos\phi > 0.4$
-Burner motor:	3 A	$\cos\phi > 0.4$
-Alarm:	1 A	$\cos\phi = 1$
-Ignition transformer:	2 A	$\cos\phi > 0.4$
<b>Fuse rating internal:</b>	6.3 A T	
<b>Fuse rating external:</b>	5 A F	

**Flame control:**

The ionization flame detecting device makes use of the rectification property of the flame.

The ionization flame detecting device is not a safe-to-touch output (no provision with protective impedance).

- Minimum ionization current: 1.2µA  
on request: 0.5µA
- Recommended ionization current:  
≥10 times the minimum ionization current
- Minimum insulation resistance of cable and detection electrode to earth: ≥50MΩ
- Max. parasitic capacitance of detection electrode:  
≤1nF
- Max. short circuit current: < 200µA AC

**Weight** including socket: 250g

**CONSTRUCTION**

A special building technique and the surface mounting technology for the electronic components have allowed to realize a box structure and to maintain the dimensions of the previous mechanical controls unchanged.

The enclosure protects the control from mechanical damage, dust and dirt from the conditions of installation.

A varistor protects the control from voltage transients on the mains supply.

A fuse protects the internal relay of the control box in case of short circuits on the outputs (gas valves, motor, transformer and lock-out signal). This is not an accessible fuse and the control must be protected with a fuse of the fast blow type suitable to the loads connected and never exceeding 5A.

**OVERALL DIMENSIONS**

Fig. 1 shows the control overall dimensions.

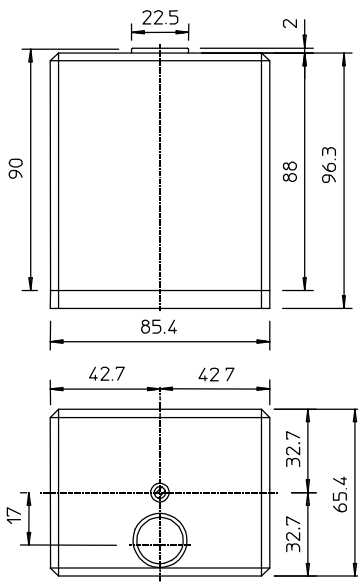

Fig.1

**ACCESSORIES**

The controls are supplied with inbuilt reset button; the enclosures are arranged for the fitting of strain relieves and/or cable holders on the sides (see fig.2).

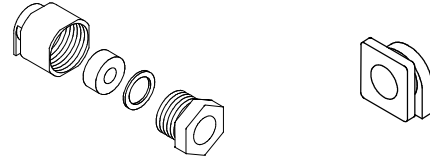

Fig.2

**WIRING**

The length of the cables of external components should not be longer than 1 m.

For the wiring of the controls you can use connecting sockets of our production.

Socket N is suitable for the VM41 control, socket NE is suitable for the VM42 control.

Fig.3 shows these accessories and all relevant dimensions, useful for the installation.

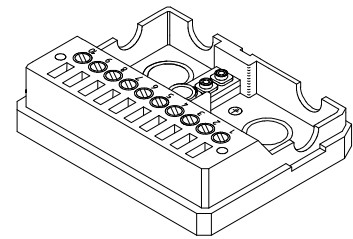

Socket N

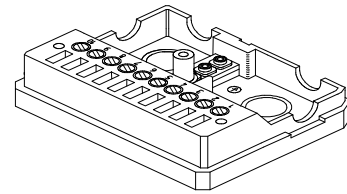

Socket NE

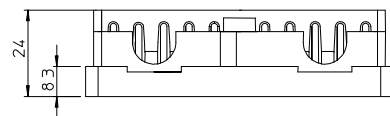

Socket N

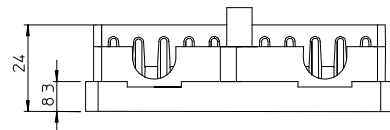

Socket NE

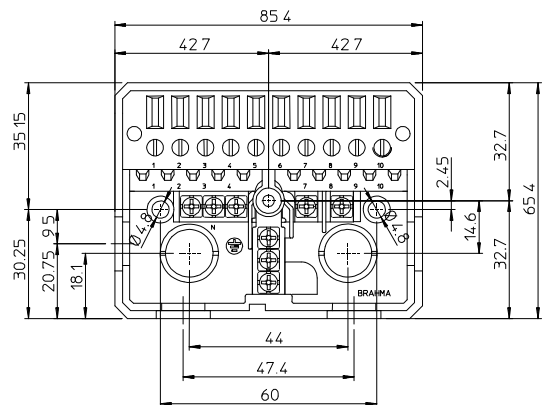

Fig.3

Regarding the connection of the control units, provisions such as strain reliefs, sufficient earth terminals and neutral terminals should be present in the appliance or in external connection boxes.

### DIRECTIONS FOR THE INSTALLATION

- For technical-safety reasons a regulation shutdown must occur every 24 hours (systems for non-permanent operation).
- Automatic controls are safety devices and shall not be opened. Responsibility and guarantee of the manufacturer is invalidated if the control is opened.
- The control must be connected and disconnected only with the supply disconnected.
- The control can be mounted in any position.
- Avoid exposure to dripping water.
- Ventilation with the lowest temperature ensures the longest life of the control.
- Make sure that the type (code and times) you are using is correct before installing or replacing the control.

### ELECTRICAL INSTALLATION

- The national and European applicable standards (e.g. EN 60335/1prEN 50165) concerning electrical safety must be respected.
- **Live** and **neutral** should be connected correctly, a mistake could cause a dangerous situation, i.e. the control and valves would still be live with the thermostats and limits switched off. Besides, if **live-neutral** polarity is not respected the control locks out after TS.
- Before starting check the cables carefully. Wrong connections can damage the control and compromise the safety.
- The earth terminal of the control, the metal frame of the burner and the earth on the mains supply must be well connected.
- Avoid putting the detection cable close to power or ignition cables.
- Use a heat resistant cable and detection probe, well insulated to ground and protected from possible moisture (or water in general).

In case of **live-neutral** network with unearthed **neutral** or **live-live** network (with center of the star not earthed) the control can operate correctly by means of an inbuilt resistor.

In the event of bad insulation between **live(s)** and earth the voltage on the ionization probe can be reduced until it causes the control to lock-out. In the presence of this kind of network it is advisable to use our transformer type AR1 (booster).

### CHECKING AT START

Always check the control before the first start and also after amendments or a long period of no operation of the system.

Before any ignition attempt make sure that the combustion chamber is free from gas.

Then make sure that:

- if the attempt to start occurs without gas supply the control locks out after TS;
- when stopping the gas flow (while the control is in operational state) supply to the gas valve is interrupted within 1 second and, after a recycling, the control proceeds to lock-out (VM41);
- when stopping the gas flow (while the control is in operational state) supply to the gas valves is interrupted within 1 second and the control proceeds to lock-out (VM42);
- operating times and sequence are suitable;
- the level of the flame signal is sufficient, see Fig.3 to execute the test;

- the intervention of limiters or safety devices causes a safety shut-down according to the application.

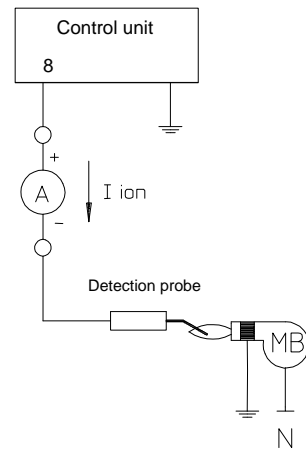

Fig.4

### OPERATION

When the thermostats close, the control gives the starting command to the burner motor and checks the position of the air pressure switch contacts; only if the test is positive with the air pressure switch in "air flow" state prepurge time (TW) begins, at the end of which the gas valve is energized and the ignition device is operated, thus starting the safety time (TS).

If a flame is detected during the safety time the ignition device is inhibited.

On the contrary, if the control does not detect a flame by the end of TS, it proceeds to non-volatile lock-out, the gas valve, the ignition device and the burner motor are switched off while the lock-out signal output is supplied.

Model VM42 controls the opening of a second gas valve 15-20 seconds after the flame detection.

If a flame failure occurs in the running position the gas valves are switched off and the VM41 proceeds to a repetition of the ignition cycle, while the VM42 proceeds to non-volatile lock-out.

The following diagrams are useful to understand the operations of the controls.

### Abnormal operation

#### - Air flow failure

VM41:

In case of failure of the air pressure switch or insufficient air flow the control proceeds to lock-out with a delay of about 15 seconds ( $t_1$  delay).

VM42:

In case of failure of the air pressure switch or insufficient air flow in the running position the control proceeds to lock-out with a delay of about 3 seconds. Air lack at start causes a lock-out within about 8 seconds ( $t_1$  delay).

**CAUTION:** If for any reason the burner system is not equipped with air pressure switch, terminals n.4 - 6 - 7 must be short-circuited.

#### - Parasitic flame

VM41:

The presence of a flame signal at start or during pre-purge time causes lock-out within about 15 seconds ( $t_2$  delay).

VM42:

The presence of a flame signal at start causes a lock-out within about 8 seconds. Parasitic flame during pre-purge causes a lock-out within about 3 seconds ( $t_2$  delay).

### RESET OF THE CONTROL

When the control has gone to lock-out a waiting time of 10 seconds should be allowed before attempting to reset the control.

# CONNECTION DIAGRAMS

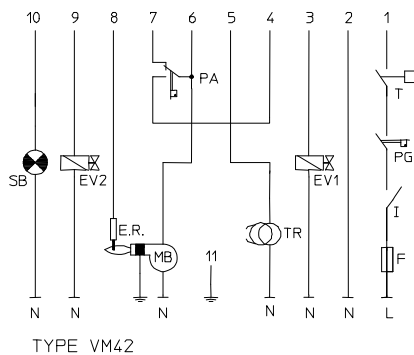
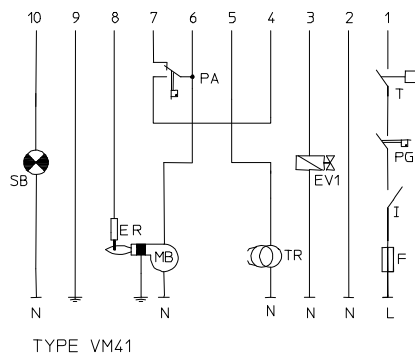

# OPERATING CYCLES

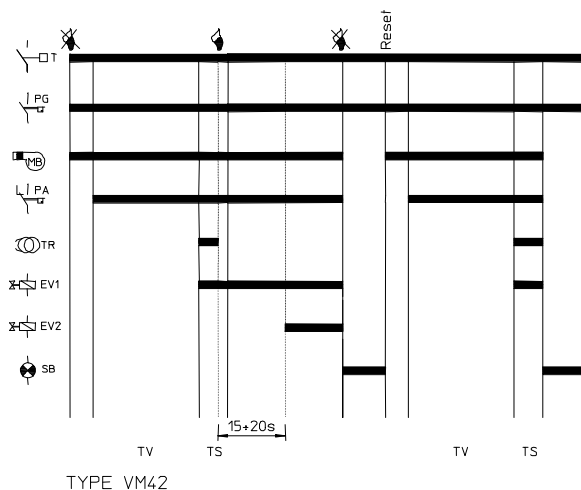
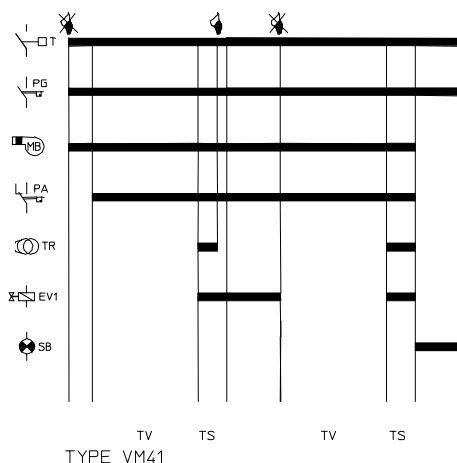

## ANOMALIES

### Lack of air

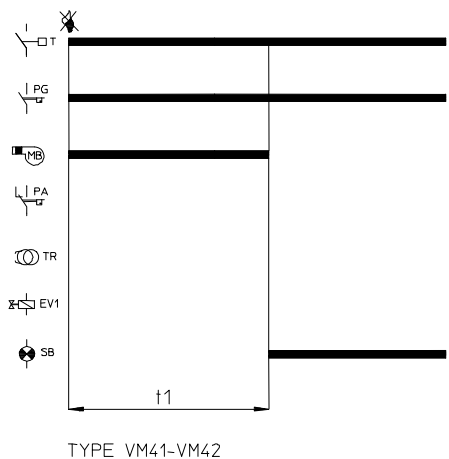

### Parasitics flame

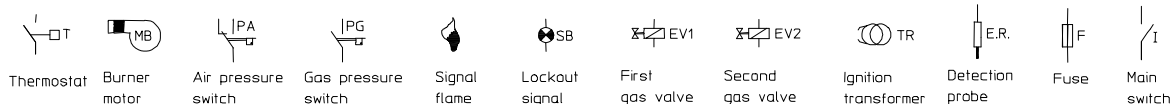
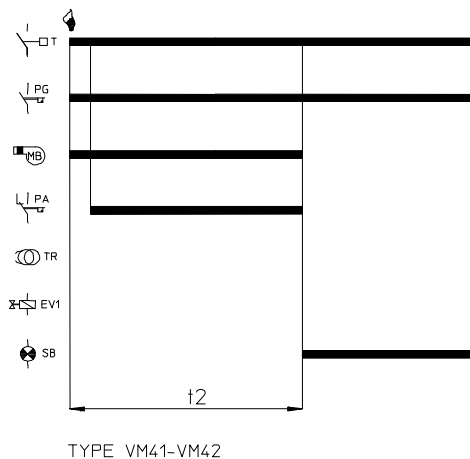

**BRAHMA S.p.A.**  
 Via del Pontiere, 31  
 37045 Legnago (VR)  
 Tel. +39 0442 635211 - Telefax +39 0442 25683  
<http://www.brahma.it>  
 E-mail : [brahma@brahma.it](mailto:brahma@brahma.it)

03/03/26 Subject to amendments without notice