

ARTICULO: 5803 – 5803L Actuador Eléctrico Rotativo GE Multivoltage GE Multivoltage Electric Rotary Actuator

Características

Diseñados para aplicaciones de 1/4 de vuelta (90°) y reversibles, ideales para la automatización de válvulas de bola y mariposas.

Existen 6 tamaños distintos de acuerdo al par de maniobra:

GE-0	GE-05	GE-1	GE-15	GE-2	GE-2+
20 Nm	35 Nm	55 Nm	85 Nm	140 Nm	300 Nm

Existen 3 modelos distintos de acuerdo a la alimentación eléctrica y tamaño del actuador:

Modelo	Voltaje	Tamaño
“ S “	24 – 240 VCC / VCA	GE-0 / GE-05 / GE-1 / GE 15
“ L “	24 VCC / VCA	GE-2 / GE-2+
“ H “	85 – 240 VCC / VCA	GE-2 / GE-2+

VENTAJAS:

Resistente a la corrosión.
Fijación ISO 5211.
Protección IP-67.
Mando manual de emergencia.
Indicador óptico de posición.
2 contactos adicionales de final de carrera.
Control térmico de la temperatura:
Resistencia Calefactora de 3,5 W para el mantenimiento de la temperatura interior entre 20° y 30° C y evitar daños por condensación.

Control electrónico de par:
Cuando el par excede el máximo permitido el sistema suspende la alimentación eléctrica al motor para prevenir daños posibles.

LED indicador de funcionamiento.

Features

Designed for applications of 1/4 turn (90°) and reversible, ideal for the electric automation of ball valves and butterfly valves.

There are 6 different sizes according to operational torques:

GE-0	GE-05	GE-1	GE-15	GE-2	GE-2+
20 Nm	35 Nm	55 Nm	85 Nm	140 Nm	300 Nm

There are 3 different models according to the currents range and size of actuator:

Model	Voltage	Size
“ S “	24 – 240 VDC / VAC	GE-0 / GE-05 / GE-1 / GE 15
“ L “	24 VDC / VAC	GE-2 / GE-2+
“ H “	85 – 240 VDC / VAC	GE-2 / GE-2+

ADVANTAGES:

*Corrosion Resistant.
Fixation ISO 5211.
Protection IP-67.
Manual Override.
Optic indicator of position
2 additional contacts of final of career.
Automatic temperature control:
An internal 3,5 W thermostatically controlled heater maintains the internal temperature between 20° and 30° C eliminating the damage by condensation.*

*Electronic torque limiter:
Should the maximum torque be exceeded the system cuts the power to the motor to prevent damage to the actuator.*

LED visual control of operation.



CARACTERÍSTICAS TÉCNICAS - TECHNICAL CHARACTERISTICS

DESCRIPCION / DESCRIPTION	UNID. / UNITS	MODELOS - MODELS					
		GE-0 (type S)	GE-05 (type S)	GE-1 (type S)	GE-15 (type S)	GE-2 (type L/H)	GE-2+ (type L/H)
TIEMPO MANIOBRA EN VACIO (90°) +/- 10 % OPERATION TIME NO LOAD (90°) +/- 10%	Seg./ Sec.	10	10	14	30	34	58
PAR MANIOBRA EN OPERACIÓN OPERATING TORQUE	Nm	20	35	55	85	140	300
PAR MÁXIMO ARRANQUE MAXIMUM TORQUE BREAK	Nm	25	38	60	90	170	350
TIEMPO BAJO TENSIÓN DUTY RATING	%	75 %					
PROTECCIÓN IEC 60529 IP RATING IEC 60529	---	IP-67					
ÁNGULO MANIOBRA WORKING ANGLE	° (grados)	90° (Opcion 180° - 270°)					
TEMPERATURA DE TRABAJO WORKING TEMPERATURE	°C	-20° +70°					
INTERRUPTOR FINAL DE CARRERA LIMIT SWITCH	---	4 SPDT micro (2 paros motor y 2 confirmación / 2 motor stop and 2 confirmations)					
RESISTENCIA CALEFACTORA ANTI-CONDENSATION HEATER	W	3,5					
CONECTORES PLUGS	---	EN 175301-803					
PESO WEIGHT	Kg	1,8	1,9	2,4	3	5,2	5,2
VOLTAJE VOLTAGE	V	SERIE " S ": 24 a 240 VAC / VDC 50 / 60 Hz				SERIE " L " 24 VAC / VDC 50 / 60 Hz SERIE " H " 85 a 240 AC / DC 50 / 60 Hz	

DESCRIPCION / DESCRIPTION	UNID. / UNITS	MODELOS – MODELS						
		Corriente / Current	GE-0 (type S)	GE-05 (type S)	GE-1 (type S)	GE-15 (type S)	GE-2 (type L/H)	GE-2+ (type L/H)
CONSUMO A PAR MÁXIMO DE OPERACIÓN / CONSUMPTION AT MAXIMUM OPERATIONAL TORQUE (+/- 5 %)	A / W	24 VDC	0.80 / 19.30	1.20 / 27.60	1.21 / 29.00	0.88 / 21.20	1.78 / 42.80	2.09 / 50.20
		48 VDC	0.40 / 18.00	0.50 / 24.40	0.56 / 27.00	0.44 / 21.20		
		110 VDC	0.10 / 13.30	0.20 / 18.20	0.17 / 18.20	0.13 / 14.80	0.27 / 29.50	0.29 / 32.10
		24 VAC	1.10 / 25.80	1.50 / 36.40	1.69 / 40.70	1.16 / 27.70	2.18 / 52.30	2.71 / 65.10
		48 VAC	0.70 / 31.30	0.90 / 41.90	0.97 / 46.50	0.28 / 33.10		
		110 VAC	0.30 / 27.60	0.30 / 37.30	0.36 / 39.20	0.26 / 29.00	0.50 / 55.10	0.57 / 62.90
		240 VAC	0.20 / 37.50	0.20 / 45.90	0.20 / 47.50	0.16 / 38.00	0.30 / 65.60	0.34 / 75.00

Materiales Constructivos

Tapa :	Poliamida A6
Carter:	Poliamida A6
Levas internas:	Poliamida A6
Ejes principales externos:	Inox / Poliamida A6
Engranajes:	Acero – Poliamida
Indicador de posición:	Poliamida + fibra de vidrio
Tortillería exterior :	Acero Inoxidable

Materials of Construction

Cover :	Polyamide A6
Body :	Polyamide A6
Internal cams:	Polyamide A6
Main externals shaft:	S.S / Polyamide A6
Gears :	Steel and – Polyamide
Position indicator:	Glass filled + Polyamide
Fastening :	Stainless Steel

Opcionales

- Bloque de Seguridad BSR (retorno emergencia por batería).
- Posicionador Digital DPS: 4-20 mA, 0-20mA, 0-10V ó 1-10V
- Posibilidad de regulación: 180° y 270°.
- Kit para cambiar a 12 VAC/VDC actuadores tipo "S".

Options

- Safety block BSR (emergency fail safe kit system by battery).
- Digital Positioner DPS: 4-20 mA, 0-20 mA, 0-10V or 1-10V.
- Possibility of regulation: 180° and 270°.
- Kit for change to 12 VAC/VDC type "S" actuators.

Fijaciones / Couplings

MODELOS	ISO 5211	DIN 3337
GE - 0	F03 / 04 / 05	Doble cuadrado / Double Square 14 mm
GE - 05	F03 / 04 / 05	Doble cuadrado / Double Square 14 mm
GE - 1	F05 / 07	Doble cuadrado / Double Square 17 mm
GE - 15	F05 / 07	Doble cuadrado / Double Square 17 mm
GE - 2	F07 / 10	Doble cuadrado / Double Square 22 mm
GE - 2+	F07 / 10	Doble cuadrado / Double Square 22 mm

LED Indicador de Funcionamiento / LED visual control of operation

Características	Features
<p>Es un sistema de comunicación entre el actuador y el usuario. Según el tipo de lumínica nos informa del estado de funcionamiento del actuador.</p>	<p><i>The LED status light provides visual communication between the actuator and the user. According to the type of light informs us of the state of operation of the actuator.</i></p>

Estado / Status	Configuración LED RGB / RGB LED Configuration
<p>Actuador sin alimentación / <i>Actuator without power</i></p>	<p>Led apagado / <i>Led OFF</i></p>
<p>Actuador con alimentación / <i>Actuator with power</i></p>	<p>Actuador Abierto = Led Verde / <i>Open actuator = Green led</i> Actuador Cerrado = Led Rojo / <i>Close actuator = Red led</i></p>
<p>Actuador en movimiento (led intermitente) / <i>Actuator in moving (flashing led)</i></p>	<p>De abrir a cerrar = rojo / naranja / <i>From open to close = Red / orange</i> De cerrar a abrir = verde / naranja / <i>From close to open = Green / orange</i></p>
<p>Actuador limitado por par (led intermitente) / <i>Actuator with torque limiter activated (flashing led)</i></p>	<p>De abrir a cerrar = rojo / apagado / <i>From open to close = Red / off</i> De cerrar a abrir = verde / apagado / <i>From closet o open = Green / off</i></p>
<p>Mando manual accionado / <i>Manual mode Off</i></p>	<p>Naranja / apagado (secuencia simetrica) <i>Orange / off (symmetric sequence)</i></p>
<p>Actuador sin alimentación. BSR activado / <i>Actuator without power. BSR Activated</i></p>	<p>BSR NC = Rojo / apagado / <i>BSR NC = Red / off</i> BSR NA = Verde / apagado / <i>BSR NO = Green / off</i></p>
<p>Protección batería, baja de carga. BSR bloqueado / <i>Battery protection, needs recharging. BSR blocked</i></p>	<p>Naranja / apagado (secuencia asimetrica) <i>Orange / off (asymmetric sequence)</i></p>
<p>Actuador con posicionador DPS / <i>Actuator with DPS Positioner</i></p>	<p>Parado = Azul / <i>Stop = Blue</i> Abriendo = Azul / Verde / <i>Opening = Blue / Green</i> Cerrando = Azul / Rojo / <i>Closing = Blue / Red</i></p>

Dimensiones Generales / General Dimensions (mm / inch)

GE – 0 / GE – 05

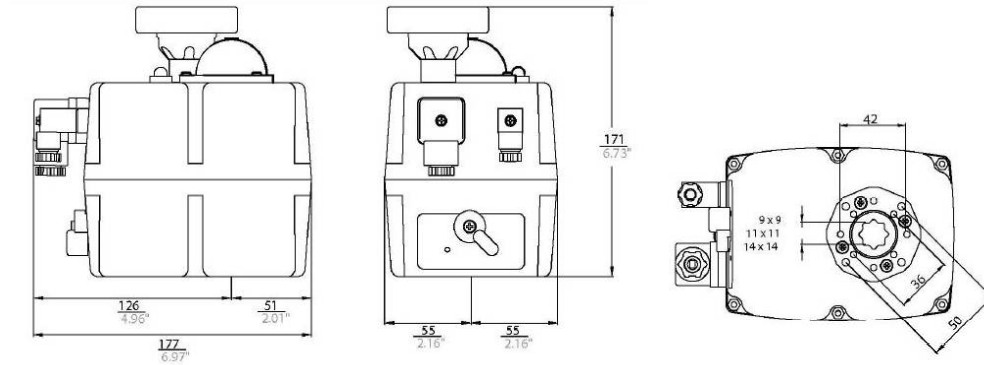

GE – 1

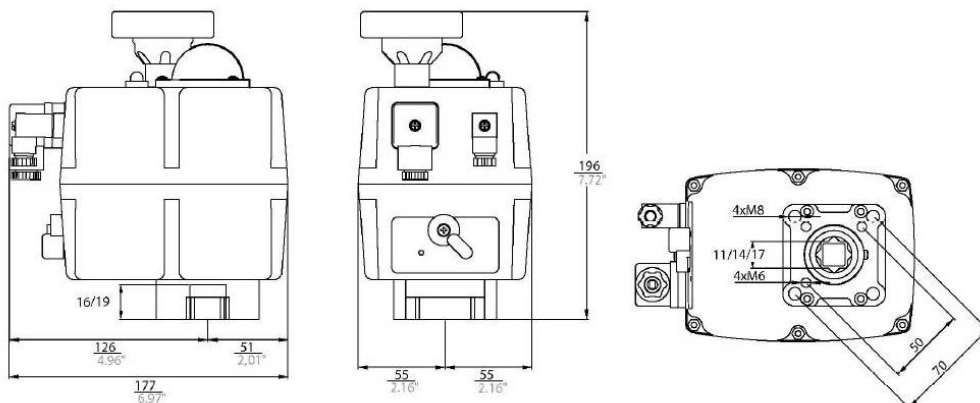

GE – 15

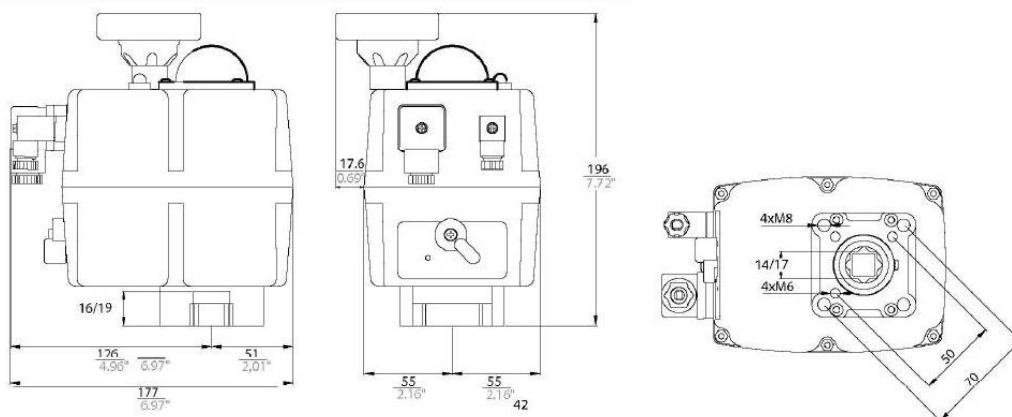

GE - 2 / GE - 2+

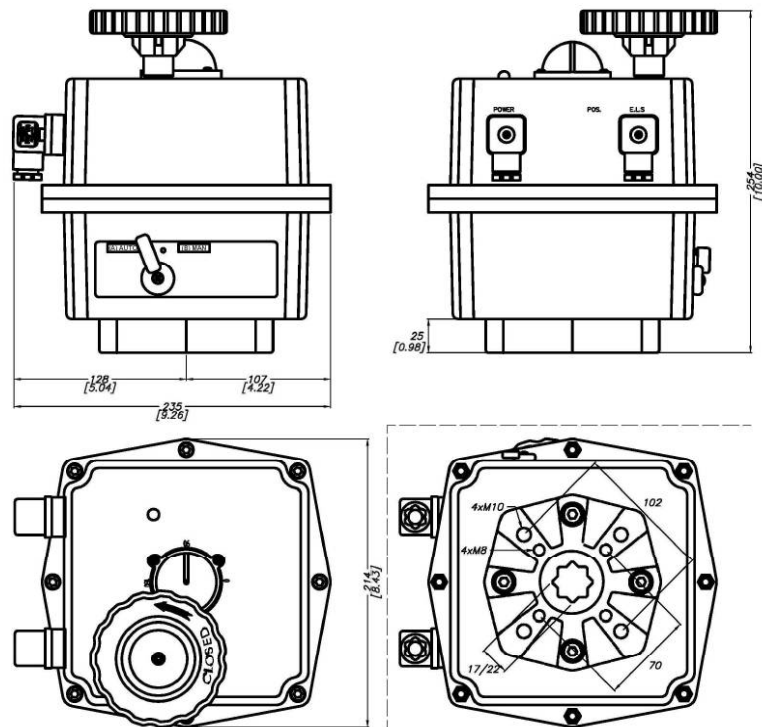

Esquema Externo de Conexiones / External Electric Wiring

ABRE - CIERRA / ON - OFF

3 hilos / 3 wires (VAC or VDC):

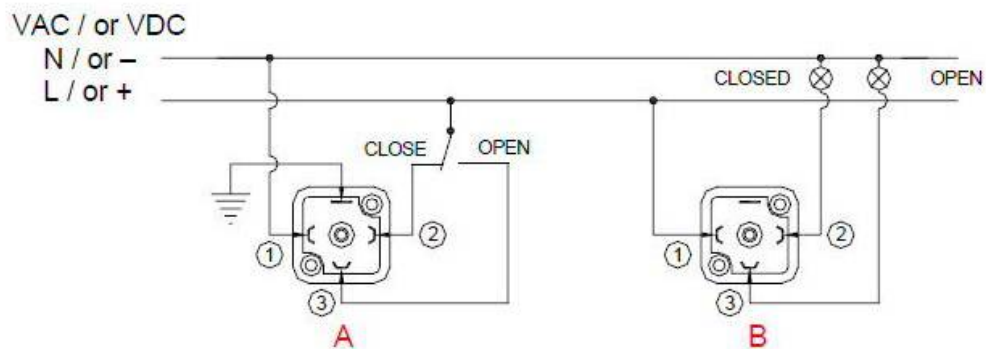

Conector A (Color Gris) / A Plug (Grey Color) = Alimentación Eléctrica / Power Supply

A: VAC 3 cables / VAC 3 wires

PIN 1 = Neutro / Neutral + PIN 2 = Fase / Phase = Cierra / Close

PIN 1 = Neutro / Neutral + PIN 3 = Fase / Phase = Abre / Open

A: VDC 3 cables / VDC 3 wires

PIN 1 = (-) Negativo / Negative + PIN 2 = (+) Positivo / Positive = Cierra / Close

PIN 1 = (-) Negativo / Negative + PIN 3 = (+) Positivo / Positive = Abre / Open

Conector B (Color Negro) / B Plug (Black Color) = Contactos Auxiliares / Volt free Contacts

B: PIN 1 / PIN 2 = Cerrado / Closed

PIN 1 / PIN 3 = Abierto / Open

2 hilos / 2 wires (VDC):

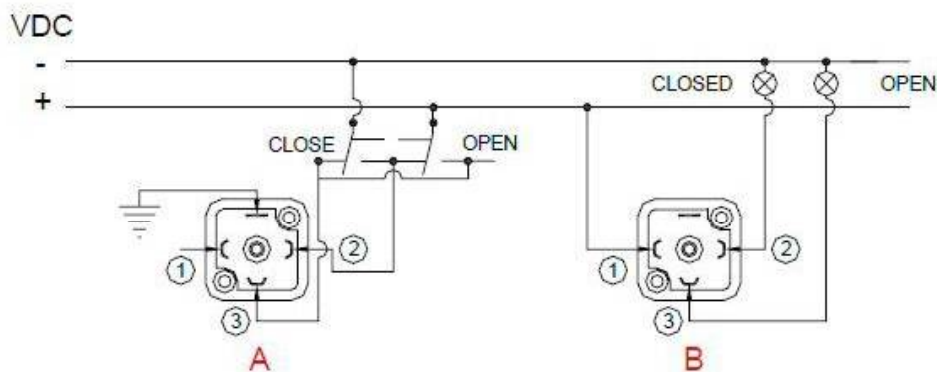

Conector A (Color Gris) / A Plug (Grey Color) = Alimentación Eléctrica / Power Supply

A: VDC 2 cables / VDC 2 wires

PIN 2 = (+) Positivo / Positive + PIN 3 = (-) Negativo / Negative = Cierra / Close

PIN 2 = (-) Negativo / Negative + PIN 3 = (+) Positivo / Positive = Abre / Open

Conector B (Color Negro) / B Plug (Black Color) = Contactos Auxiliares / Volt free Contacts

B: PIN 1 / PIN 2 = Cerrado / Closed

PIN 1 / PIN 3 = Abierto / Open